

12  
VOLT

# GATE OPERATOR R40

For gate leaves up to 3,5 m

EN  
12445  
12453  
COMPLIANT

## 650R40

12 V electromechanical gate operator with encoder. Maximum gate leaf 3,5 m / 400 kg (foundation box to be ordered separately)

### Features:

- residential / apartment building use
- for gates leaves up to 3,5 m
- low voltage DC gate operator
- optical encoder technology
- electromechanical motor
- protection degree IP67

### Pros:

- virtually invisible, does not affect the design of the gate
- opening up to 180° thanks to the optional 700KIT180 kit
- obstacle detection and crush prevention
- in accordance with EN 12445-12453 standards
- works even in case of a power cut thanks to the optional battery pack
- works even during power outage thanks to the optional backup battery
- fast operating speed
- intensive use, ideal for use on apartment buildings and public entrances
- watertight for reliable operation



**Watertight**  
Water proof design ensuring a complete and lasting protection.



**Stainless Steel Box**  
The stainless steel foundation box ensures the highest resistance from corrosion.



Technical features	R40
Power supply	230 V AC (50 - 60 Hz)
Motor power supply	18 V DC
Absorption	1,5 A
Absorbed power	28 W
Opening time 90°	18 sec.
Duty cycle	100 %
Max. torque	458 Nm
Operating temperature	-20° C ÷ +55° C
Motor thermal protection	-
Degree of protection	IP 67

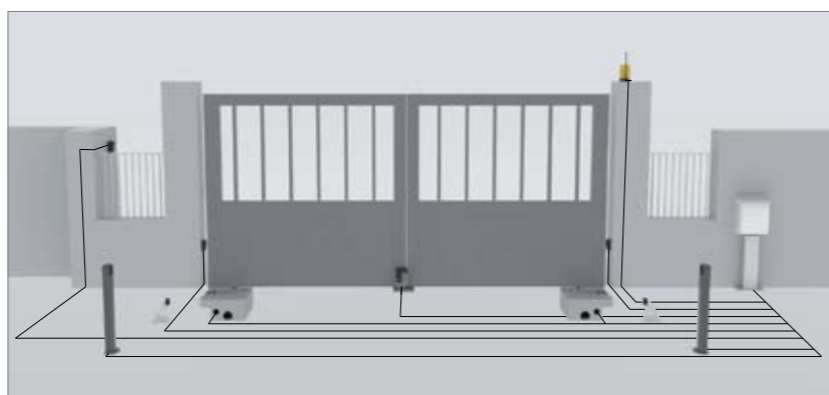

The above represented installation does not include safety devices such as safety edges. Their addition depends upon the risk assessment made on any installation in accordance with EN 12445-12453 standards.

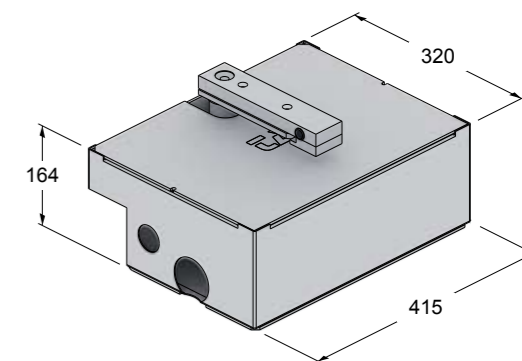

### Accessories



700CFR40C  
Hot-dip galvanized foundation box with release system



750D747M  
Electronic control unit for one or two 12 V gate operators with encoder, complete with transformer and enclosure



700CFR40X  
Stainless steel foundation box with release system



750SCB12  
Battery charger (optional)



S-700CFR4060  
Stainless steel cover lid for foundation box



200BATT  
12 Volt Battery, 7,2 Ah



700KIT180  
180° opening kit



700GS5  
Weatherproof cable connector for 5-core 12 V cable



700KITBFR  
Adjustable mechanical stop lever



650ESV1-2  
Electric lock (1 = left hand opening - 2 = right hand opening)



M-030000CC50  
Multicore cable (2 x 2.5 sq.mm + 3 x 0.5 sq.mm)



C-TARG  
Aluminium CE Mark Label, self adhesive

⚠ Use only M-030000CC50 cable or equivalent

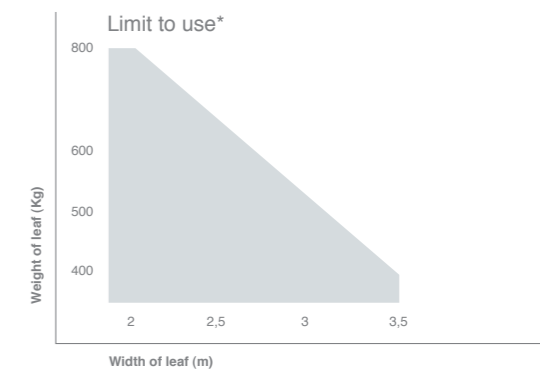

\*They refer to leaves with openings and not totally closed panels.

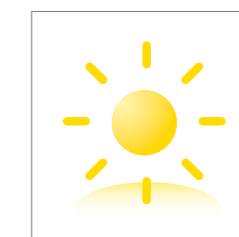

**Solar power**  
Thanks to the Photovoltaic (PV) Technology, every low voltage DC gate operator can be solar powered. Discover the advantages of the solar energy at page 124



**Further accessories:**  
Transmitters page 104  
Photocells page 110  
Flashing lights page 113

# GATE OPERATOR R30

For gate leaves up to 3,5 m

## 650R30

230 V electromechanical gate operator. Maximum gate leaf 3,5 m / 400 kg (foundation box to be ordered separately)

### Features:

- residential use
- for gates leaves up to 3,5 m
- 230 V gate operator
- electromechanical motor
- protection degree IP67

### Pros:

- virtually invisible, does not affect the design of the gate
- opening up to 180° thanks to the optional 700KIT180 kit
- watertight for reliable operation
- manual release
- high torque and power
- suitable for large gates and non standard sized posts



**Watertight**  
Water proof design ensuring a complete and lasting protection.



**Stainless Steel Box**  
The stainless steel foundation box ensures the highest resistance from corrosion.

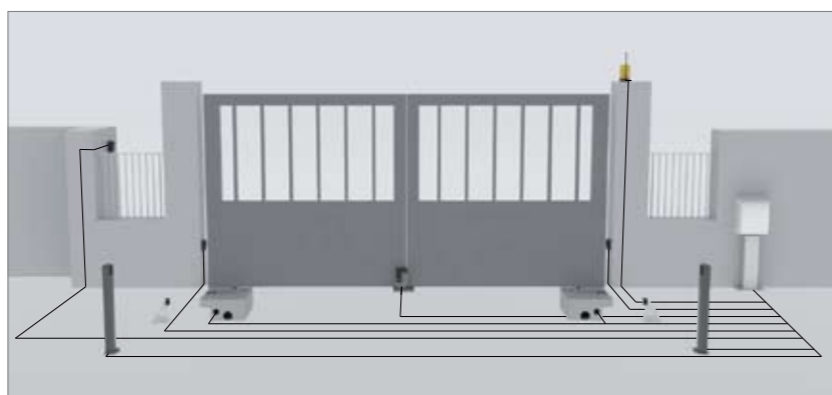

Technical features	R30
Power supply	230 V AC (50 - 60 Hz)
Motor power supply	230 V AC
Absorption	1,4 A
Absorbed power	260 W
Opening time 90°	16,5 sec.
Duty cycle	33 %
Max. torque	402 Nm
Operating temperature	-20° C ÷ +55° C
Motor thermal protection	160° C
Degree of protection	IP 67

The above represented installation does not include safety devices such as safety edges. Their addition depends upon the risk assessment made on any installation in accordance with EN 12445-12453 standards.

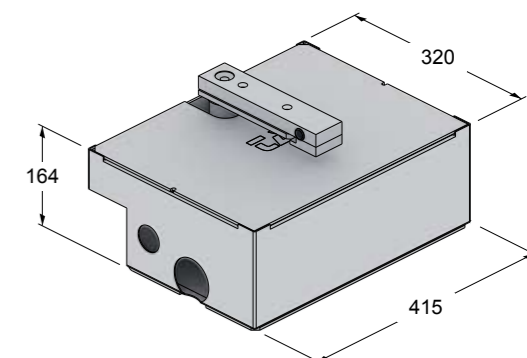

### Accessories



700CFR40C  
Hot-dip galvanized foundation box with release system



S-750D752M10  
Control unit enclosure protective lid



700CFR40X  
Stainless steel foundation box with release system



700GS3  
Weatherproof cable connector for 3-core 230 V cable



S-700CFR4060  
Stainless steel cover lid for foundation box



650ESV1-2  
Electric lock (1 = left hand opening - 2 = right hand opening)



700KIT180  
180° opening kit



700BAP  
Gate stopper for heavy leaves



700KITBFR  
Adjustable mechanical stop lever



700BAP2  
Gate stopper wall/floor mount



750D750M  
Electronic control unit for one or two 230 V gate operators with soft-stop and built-in 433,92 MHz radio receiver, complete with enclosure



C-TARG  
Aluminium CE Mark Label, self adhesive

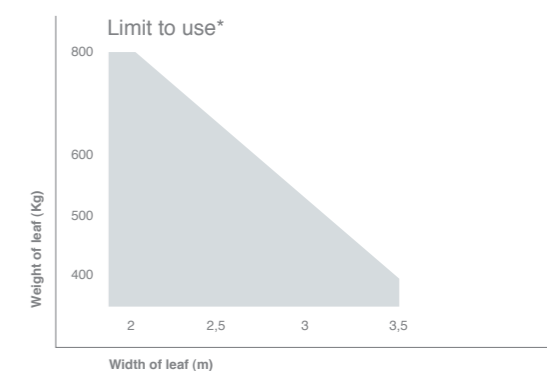

\*They refer to leaves with openings and not totally closed panels.



**Further accessories:**  
Transmitters page 104  
Photocells page 110  
Flashing lights page 113